



www.pollardbros.com



### Industrial Shop Stool - 300

Rugged 3/4" x 3/4" x 1/8" Angle Iron and mitred 1" x 1/8" Strip Steel are riveted and welded together for superior strength and day-in and day-out use from all of Pollard's shop stools. The 14" diameter x 1-1/4" thick wood stool seat is made from laminated maple and has a (2) coat clear varnish finish. Unfinished wood stool seats, as well as additional stain options, and red oak wood seats are available, please contact office for additional information. Standard steel stool feet at base of frame are dimpled to protect floors; non-marring nylon leveling glides and swivel hard rubber casters are available on both fixed and adjustable height stools for additional surface protection and mobility. Adjustable height and stationary wood seat shop stools have a 400 lb capacity. Heavy Duty wood seats with an 18" diameter and an 800 lb capacity are also available. Swivel seat option available as well. For point of reference, stool seat height should be 10" below table top surface. These stools are great in the factory, office, workshop, garage, lab or loft; anywhere a classic comfortable seat is needed.

Example Order Number:

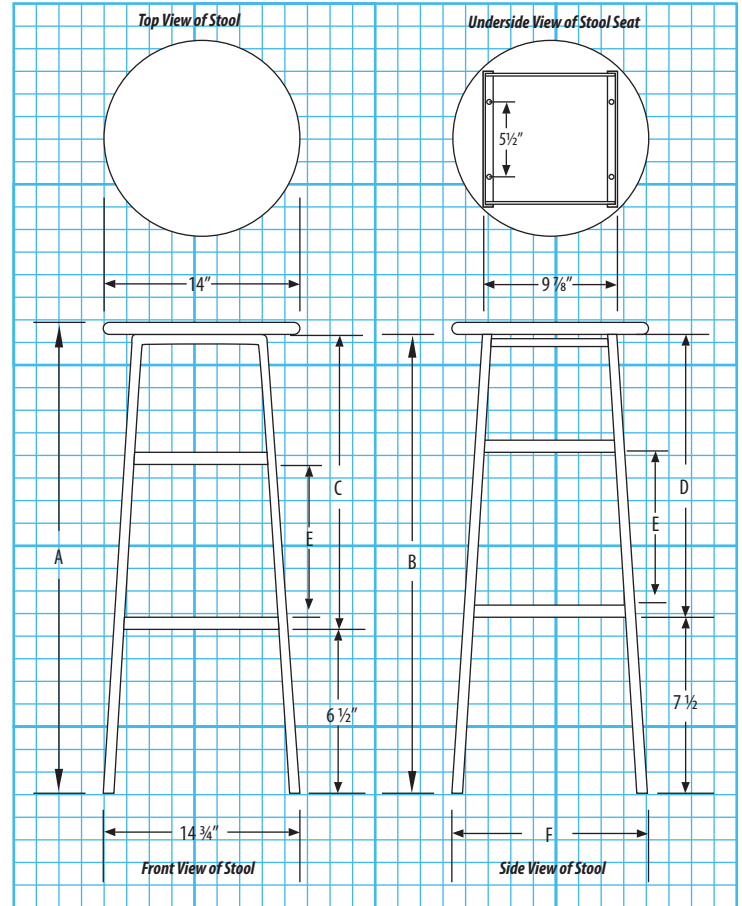
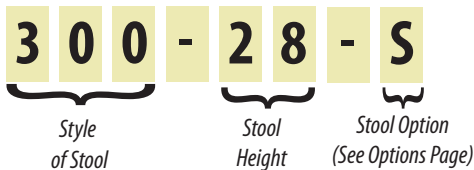

Stool Height Specs					
Overall Height (A)	Frame Height (B)	Brace Height (C)	Brace Height (D)	Brace Distance (E)	Frame Base Width (F)
18 1/4"	17"	10 1/2"	9 1/2"	N/A	12 7/8"
20 1/4"	19"	12 1/2"	11 1/2"	N/A	13 1/4"
22 1/4"	21"	14 1/2"	13 1/2"	N/A	13 13/16"
24 1/4"	23"	16 1/2"	15 1/2"	N/A	14 3/16"
26 1/4"	25"	18 1/2"	17 1/2"	N/A	14 5/8"
28 1/4"	27"	20 1/2"	19 1/2"	9"	15 3/8"
30 1/4"	29"	22 1/2"	21 1/2"	10"	15 1/2"

Suggested Load Range:

400 lbs.

Pollard Brothers Manufacturing • 5504 N. Northwest Highway • Chicago • IL • 60630

phone (773) 763-6868 fax (773) 763-4466 toll free (800) 551-5566