

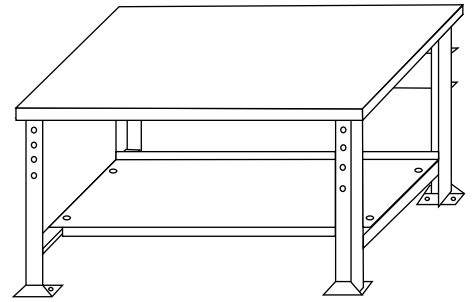

# 124, 114, & 144 - Open Leg Bench Assembly Instructions

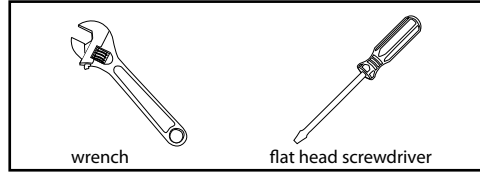

**Tools Needed:**



**Includes:**

- (2) or (3) Bench Legs
- (1) Formed Channel Stringer
- (1) Formed Shelf
- (1) Steel, Maple or Hard Top

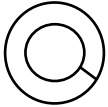
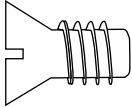
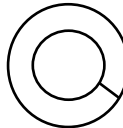
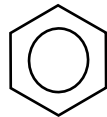
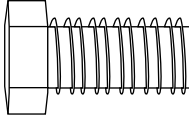
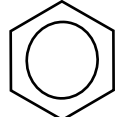
|  |   |  |
|--|---|--|
| <p><b>6</b> x </p> <p>5/16" Lock Washer</p> | <p><b>6</b> x </p> <p>5/16" x 3/4" Flat Head Machine Screw</p> | <p><b>8</b> x </p> <p>3/8" Lock Washer<br/><i>(124s only)</i></p> |
| <p><b>6</b> x </p> <p>5/16" Hex Nut</p>     | <p><b>8</b> x </p> <p>3/8" x 3/4" Hex Head Machine Screw</p>   | <p><b>8</b> x </p> <p>3/8" Hex Nut</p>                            |

*Note: (4) additional 3/8" x 3/4" Hex Head Machine Screws are provided for 8' & 10' benches.*

**Steps:**

**1**

Stand legs upright and face as shown. *Note: 6' benches and under come with two legs, and 8' benches and over come with three legs.*

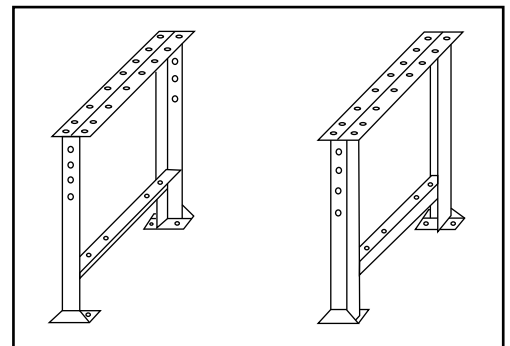

**2**

Attach stringer to the back leg uprights using (4) 3/8" x 3/4" Hex Head Machine Screws, 3/8" hex nuts, and 3/8" washers. **HAND TIGHTEN ONLY.**

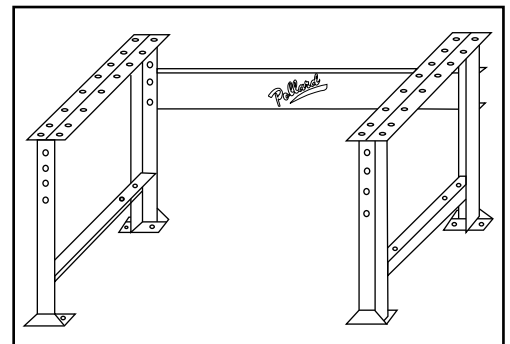

3

Attach shelf to Bench Leg crosses with the form up in the back using 3/8" x 3/4" Hex Head Machine Screws, 3/8" hex nuts, and 3/8" washers. **HAND TIGHTEN ONLY.**

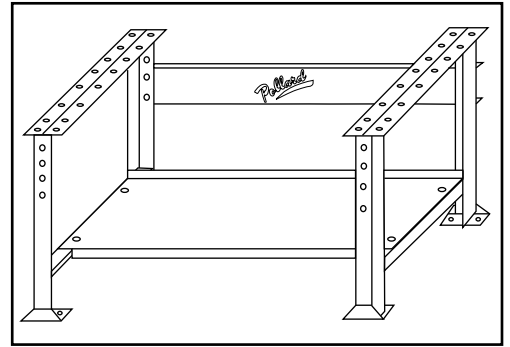

For 124s:

4

Slide Top with back plate onto legs starting at either end matching holes in Bench Leg top. Use (6) 5/16" x 3/4" Flat Head Machine Screws with 5/16" Hex Nuts and Lock Washers. **HAND TIGHTEN ONLY.**

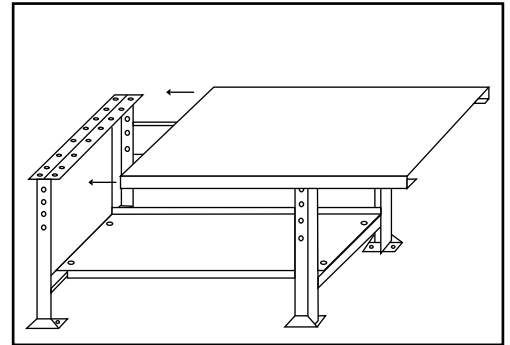

For 114s &amp; 144s:

4

When the top ordered is Lam. Maple or our Hard Top place top on bench legs matching holes and use (6) 3/8" x 2 1/2" Flat Head Machine Screws and 3/8" Hex Nuts **No Washers needed on Maple & Hard tops.**

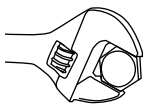
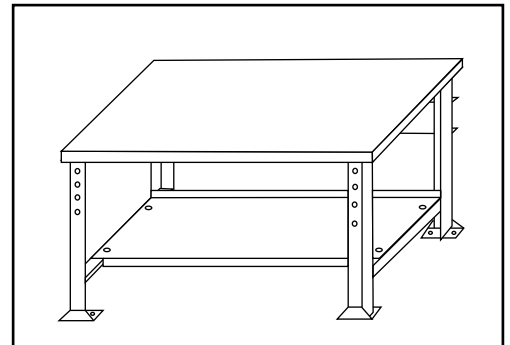

After top is in place, make sure bench is square and then, tighten all bolts, starting with the stringer and tie rods.