

146 Maple Top Open Leg Bench Assembly Instructions

Tools Needed:

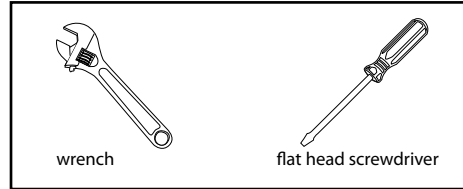

Includes:

- (2) or (3) Bench Legs • (1) Formed Channel Stringer • (1) Maple Bench Top

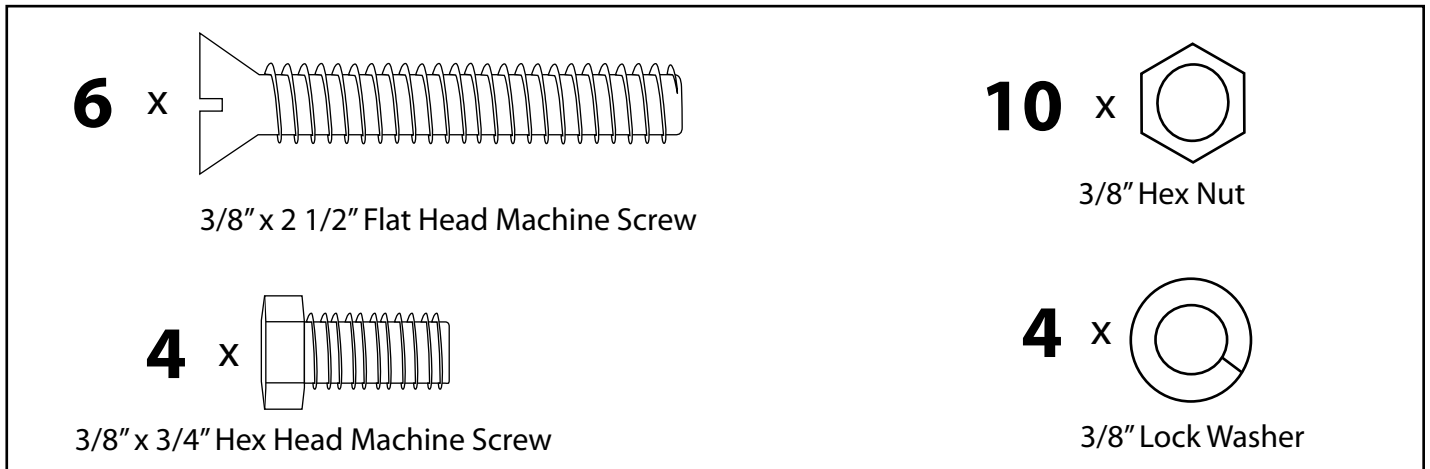

Note: Additional hardware is provided for 8' & 10' benches.

Steps:

1

Stand legs upright and face as shown. *Note: 6' benches and under come with two legs, and 8' benches and over come with three legs.*

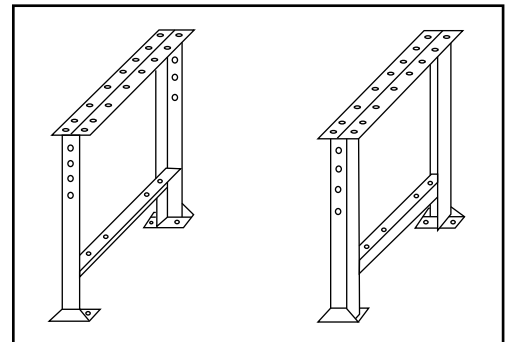

2

Attach stringer to the back leg uprights using (4) 3/8" x 3/4" Hex Head Machine Screws, 3/8" hex nuts, and 3/8" washers. **HAND TIGHTEN ONLY.**

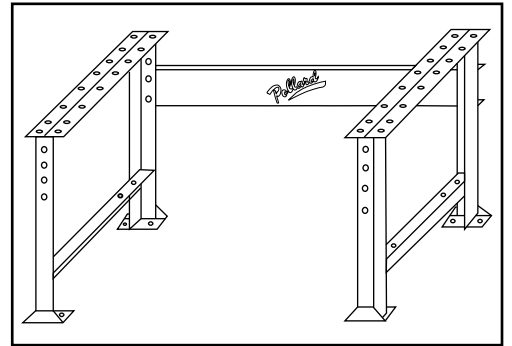

3

Place top on bench legs matching holes and use (6) 3/8" x 2 1/2" Flat Head Machine Screws and 3/8" Hex Nuts **No Washers needed.**

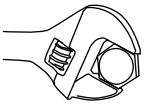
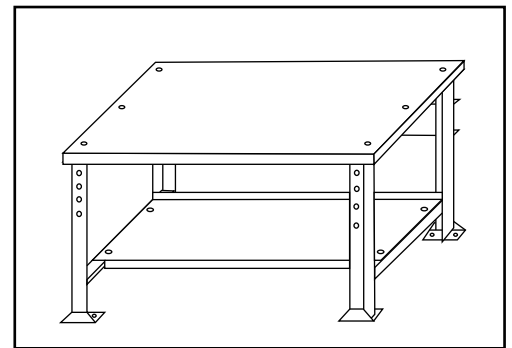

After top is in place, make sure bench is square and then, tighten all bolts, starting with the stringer.

