

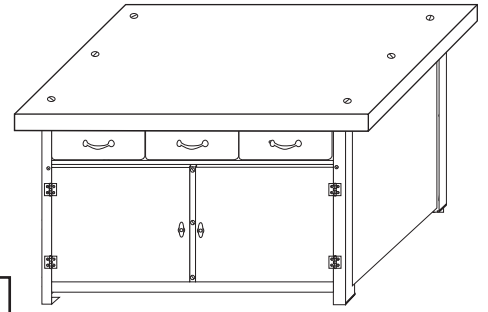

# 163-630-34 & 163-630-35 Cabinet Work Bench Assembly Instructions

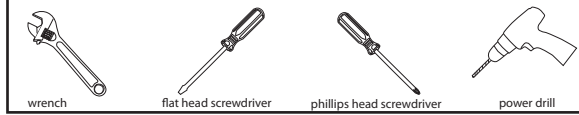

Tools Needed:



## Includes:

- (2) Cabinet Sides (Left & Right) • (1) Back Plate • (1) Kick Plate Channel • (2) Shelves • (1) Door Jam • (2) Cabinet Doors (Left & Right)
- (1) Door Center Post • (1) Maple Top • (3) Drawer Handles • (3) Drawer Covers • (3) Drawers



6 x 8/32" Hex Nut



6 x 8/32" x 3/8" Flat Head Machine Screw



22 x 1/4" x 5/8" Round Head Machine Screw



30 x #12- 3/4" Wood Screw



18 x 3/8" Hex Nut



12 x 3/8" Lock Washer

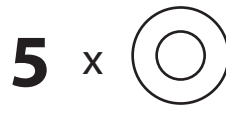

5 x Spacer

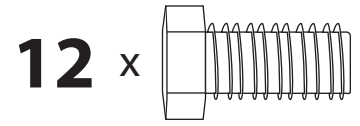

12 x 3/8" x 3/4" Hex Head Machine Screw

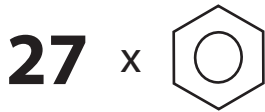

27 x 1/4" Hex Nut



27 x 1/4" Lock Washer

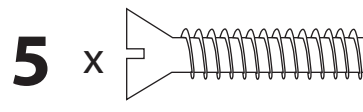

5 x 1/4" x 1 1/4" Flat Head Machine Screw

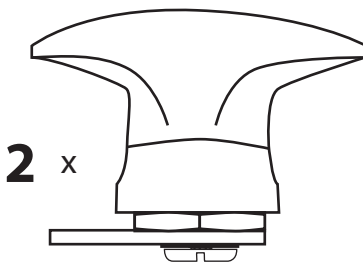

2 x

T-Handle Lock

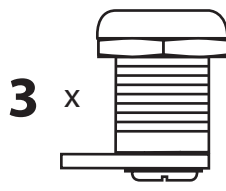

3 x

Cylinder Lock

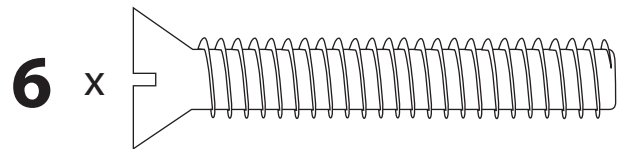

6 x

3/8" x 2 1/2" Flat Head Machine Screw

*Note: For 163-530-35 (6) 3/8" x 3 1/2" Flat Head Machine Screws will replace (6) 3/8" x 2 1/2" Flat Head Machine Screws.*

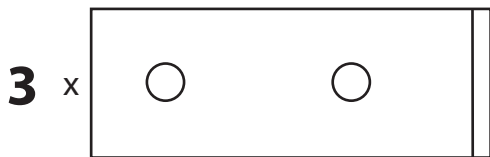

3 x

Cylinder Lock Attachment

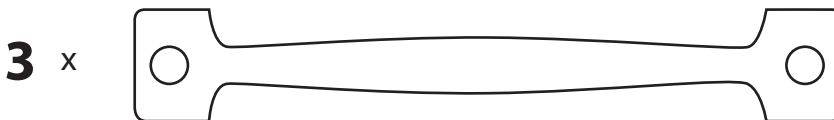

3 x

Drawer Handle

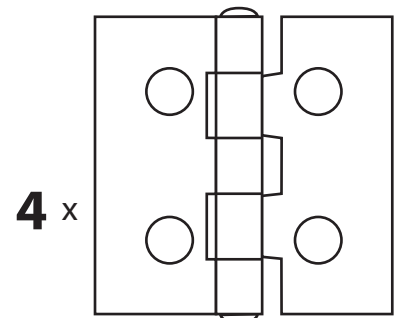

4 x

2" x 2" Butt Hinges

## Steps:

[2]

# 1

Insert Cabinet Back Plate in inside of rear flange of Left Cabinet Side. Attach Left Cabinet Side to Cabinet Back Plate using (3) 1/4" x 5/8" Round Head Machine Screws, 1/4" Hex Nuts, and 1/4" Lock Washers. Attach Right Cabinet Side the same way. *Note: Cabinet Back Plate is packaged under a sheet of cardboard, banded to the crated Maple Top.*

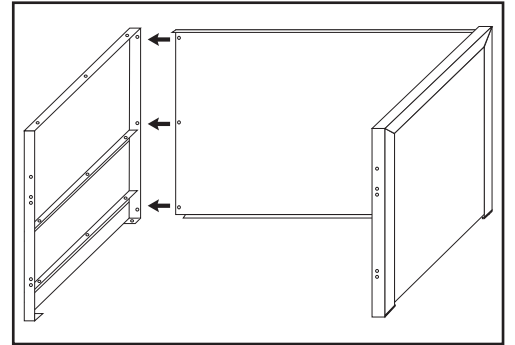

# 2

Tip Cabinet Sides and Back Plate on the back and attach one of the Cabinet Shelves to bottom cross of each side with turned down flange with 5/16" hole to the front. Fasten with (4) 3/8" x 3/4" Hex Head Machine Screws, 3/8" Hex Nuts, and 3/8" Lock Washers. Leave out Front Screws, Washers, and Nuts for Step 3.

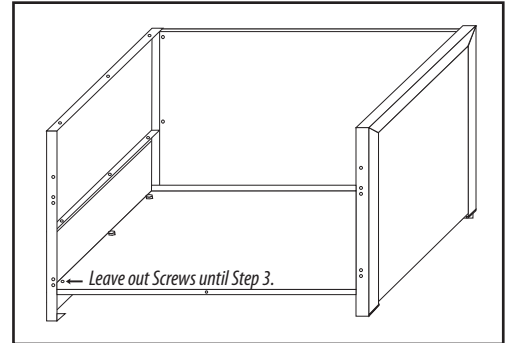

# 3

Assemble Kick Plate with flanges to the back, using (2) 3/8" x 3/4" Hex Head Machine Screws, 3/8" Hex Nuts, and 3/8" Lock Washers.

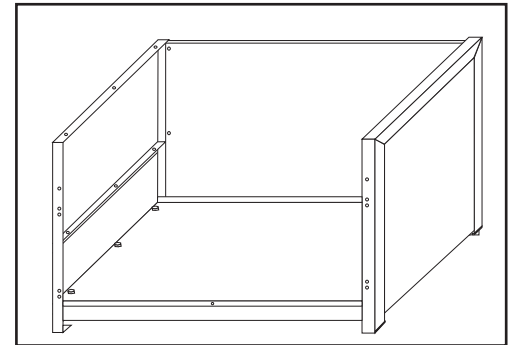

# 4

Insert second Shelf with turned down edge front and attach using (6) 3/8" x 3/4" Hex Head Machine Screws, 3/8" Hex Nuts, and 3/8" Lock Washers.

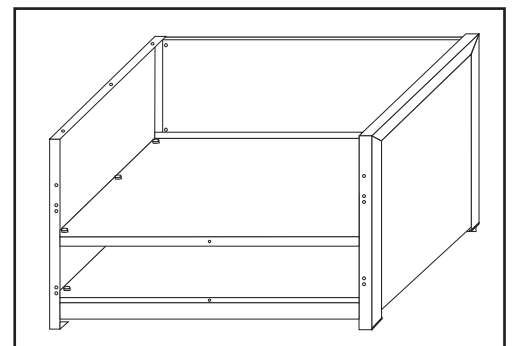

# 5

Attach Door Jam to Uprights using (2) 1/4" x 1 1/4" Flat Machine Screws, 1/4" Hex Nuts, and 1/4" Lock Washers and (2) Nylon Spacers. *Note: Spacers should be between Uprights and Door Jam.*

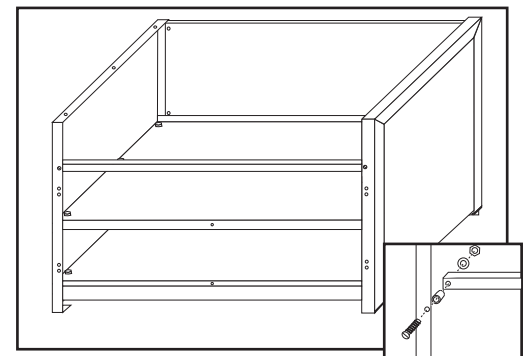

6

Attach Door Center Post to Door Jam and Shelves using (3) 1/4" x 1 1/4" Flat Head Machine Screws, Hex Nuts, and Lock Washers, and (3) Nylon Spacers. *Note: Spacers should be between Center Post and Shelves and Door Jam.*

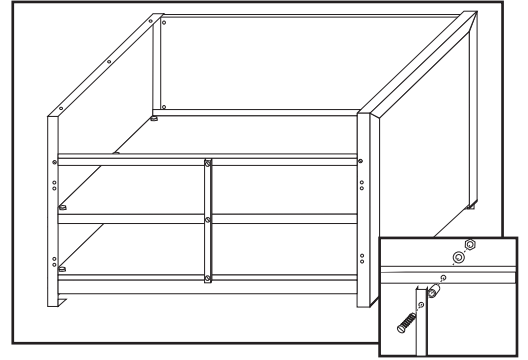

7

Attach 2" x 2" Butt Hinges to Cabinet Doors and attach to sides using (16) 1/4" x 5/8" Round Head Machine Screws, 1/4" Hex Nuts, and 1/4" Lock Washers.

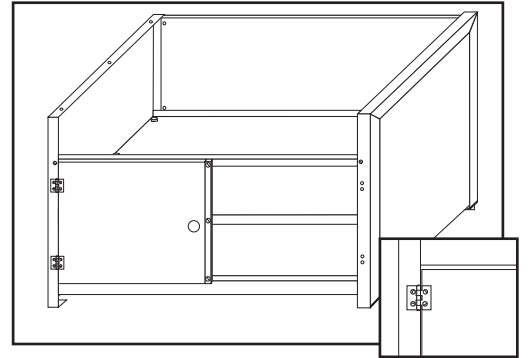

8

Pull partially assembled Bench to upright position. Square and level then tighten all screws.

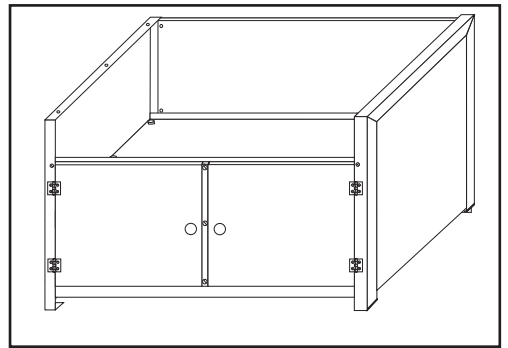

9

Attach T-Handle Locks to Cabinet Doors. Remove End Screw w/ Sem from Barrel, then remove Cam and 3/4" Hex Nut. Insert T-Handle into lock hole and reassemble Hex Nut, Cam, Sem, and End Screw according to diagram.

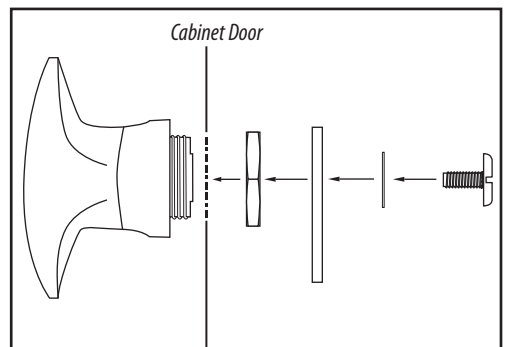

10

Remove drawer from the drawer cover. *Note: To detach the drawer pull black lever on both slides up simultaneously as you pull the drawer out.*

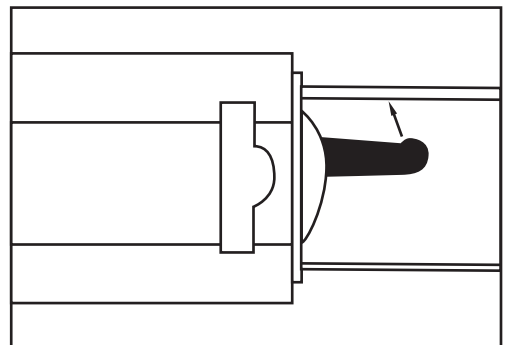

11

Attach Drawer covers and Cylinder Lock Attachment to Maple Top underside using Pilot Holes and (30) #12 3/4" Wood Screws. Verify interior spacing of 21<sup>9</sup>/<sub>16</sub>" between sides of drawer cover.

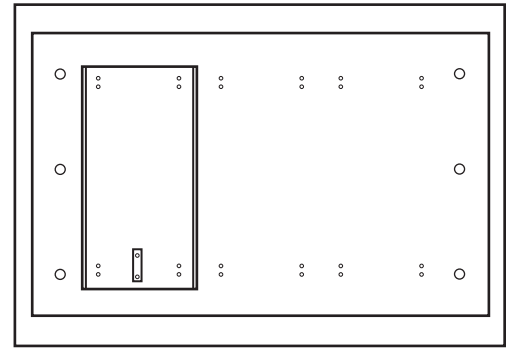

12

Turn Maple Top over and attach to Cabinet Side using (6) 3/8" x 2 1/2" Flat Head Machine Screws and 3/8" Hex Nuts. *Note: 2 5/8" thick Maple Top will use (6) 3/8" x 3 1/2" Flat Head Machine Screws.*

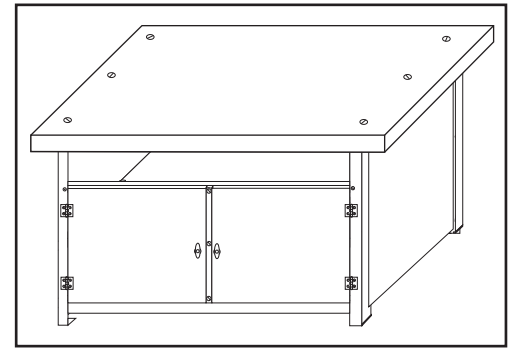

*Note: 5' Model has 3" overhang on each side of bench.*

13

After placing Maple Top on cabinet and attaching, make sure interior spacing of Drawer cover remains 21<sup>9</sup>/<sub>16</sub>". *Note: If interior drawer spacing is off, gently bend sides of drawer cover to correct measurement.*

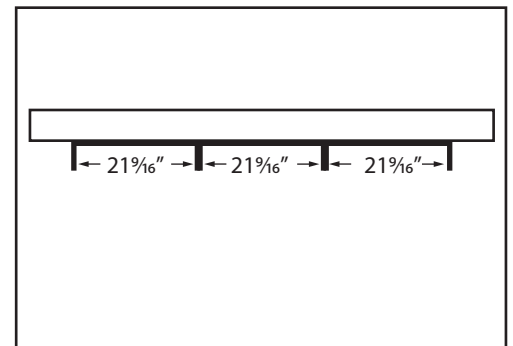

14

Attach Cylinder Locks to Drawer Fronts. Remove End Screw, Cam, and 1/2" Hex Nut from Cylinder. Insert Cylinder into lock hole and replace 1/2" Hex Nut, Cam, and End Screw according to diagram. Then attach Drawer Handles to Drawer fronts using (6) 8/32" x 3/8" Flat Head Machine Screws.

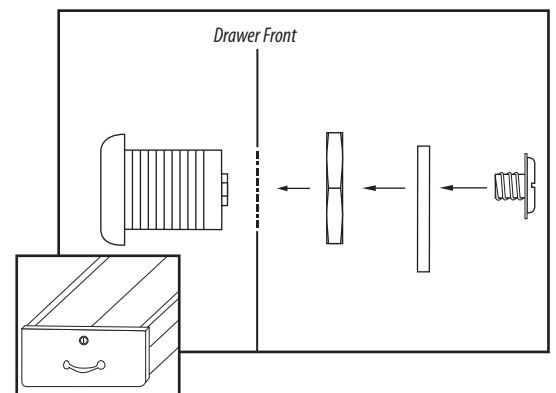

15

Carefully insert Drawer slide on drawer into the drawer slide on the drawer cover making sure slides are lined up and square. *Note: After inserting drawer, fully close drawer to ensure drawer has locked. Drawer must be inserted slowly and squarely to ensure proper attachment to drawer slide on underside of cover.*

