

216 - Riser Shelf Assembly Instructions

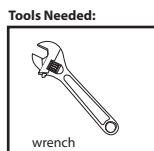

Includes:

- (2) Box Encaps
- (1) Formed Shelf
- (2) 9" Braces



1/4" x 5/8" Hex Head
Machine Screw

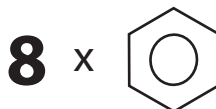

1/4" Hex Nut

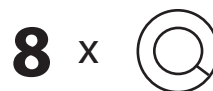

1/4" Lock Washer

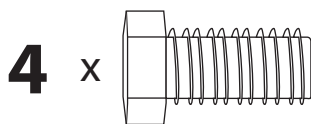

3/8" x 3/4" Hex Head
Machine Screw

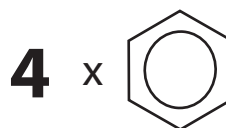

3/8" Hex Nut



3/8" Lock Washer

Steps:

1

Stand Box Endcaps on end about 8' apart and face as shown.



2

Attach Riser Shelf to Box Endcaps using (4) $\frac{1}{4}$ " x $\frac{5}{8}$ " Hex Head Machine Screws, $\frac{1}{4}$ " hex nuts, and $\frac{1}{4}$ " washers. **HAND TIGHTEN ONLY.**

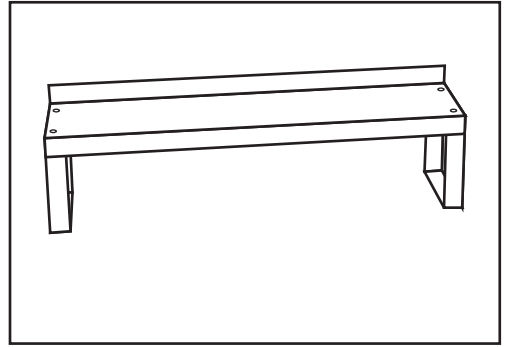

3

Attach braces to Riser shelf and Box Endcaps using (4) $\frac{1}{4}$ " x $\frac{5}{8}$ " Hex Head Machine Screws, $\frac{1}{4}$ " Hex Nuts, and $\frac{1}{4}$ " Lock Washers. **HAND TIGHTEN ONLY.**

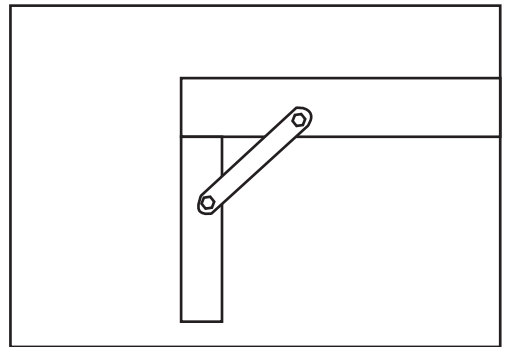

4

Attach Riser Shelf to Bench Top. Note: If Bench top is wood use (6) $\frac{1}{4}$ " Lag Screws. If Bench top is steel use (4) $\frac{3}{8}$ " x $\frac{3}{4}$ " Hex Head Machine Screws, $\frac{3}{8}$ " Lock Washers, and $\frac{3}{8}$ " Hex Nuts.

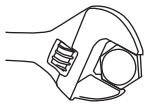
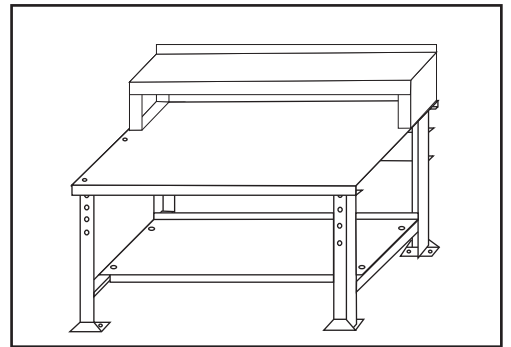

After top is in place, make sure bench is square and then, tighten all bolts, starting with the stringer and tie rods.